

11940A CLOSE-FIELD PROBE

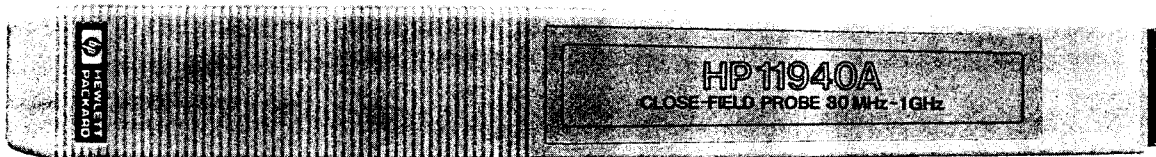

March 1986
Copyright © 1986 Hewlett-Packard Company
1212 Valley House Drive
Rohnert Park, California, 94928, U.S.A.



CERTIFICATION

Hewlett-Packard Company certifies that this product met its published specifications at the time of shipment from the factory. Hewlett-Packard further certifies that its calibration measurements are traceable to the United States National Bureau of Standards, to the extent allowed by the Bureau's calibration facility, and to the calibration facilities of the other International Standards Organization members.

WARRANTY

This Hewlett-Packard instrument product is warranted against defects in material and workmanship for a period of one year from date of shipment. During the warranty period, Hewlett-Packard Company will, at its option, either repair or replace products which prove to be defective.

For warranty service or repair, this product must be returned to a service facility designated by HP. Buyer shall prepay shipping charges to HP and HP shall pay shipping charges to return the product to Buyer. However, Buyer shall pay all shipping charges, duties, and taxes for products returned to HP from another country.

HP warrants that its software and firmware designated by HP for use with an instrument will execute its programming instructions when properly installed on that instrument. HP does not warrant that the operation of the instrument, or software, or firmware will be uninterrupted or error-free.

LIMITATION OF WARRANTY

The foregoing warranty shall not apply to defects resulting from improper or inadequate maintenance by Buyer, Buyer-supplied software or interfacing, unauthorized modification or misuse, operation outside of the environmental specifications for the product, or improper site preparation or maintenance.

NO OTHER WARRANTY IS EXPRESSED OR IMPLIED. HP SPECIFICALLY DISCLAIMS THE IMPLIED WARRANTIES OF MERCHANTABILITY AND FITNESS FOR A PARTICULAR PURPOSE.

EXCLUSIVE REMEDIES

THE REMEDIES PROVIDED HEREIN ARE BUYER'S SOLE AND EXCLUSIVE REMEDIES. HP SHALL NOT BE LIABLE FOR ANY DIRECT, INDIRECT, SPECIAL, INCIDENTAL, OR CONSEQUENTIAL DAMAGES, WHETHER BASED ON CONTRACT, TORT, OR ANY OTHER LEGAL THEORY.

ASSISTANCE

Product maintenance agreements and other customer assistance agreements are available for Hewlett-Packard products.

For any assistance, contact your nearest Hewlett-Packard Sales and Service Office. Addresses are provided at the back of this manual.

CONTENTS

1-1. General Information	1
1-2. Description	1
1-4. Options	1
1-9. Initial Inspection	1
2-1. Specifications	1
3-1. Operation	3
3-2. Theory of Operation	3
3-4. Antenna Factors	3
3-8. Power Density and Electric Field Calculations	4
3-10. Localized Field Source	5
 3-12. Test Setups	5
3-17. Measurement Techniques	7
4-1. Operation Verification	8
4-5. Return Loss Measurement Test	8
5-1. Replaceable Parts	11
5-3. SMA Adapter Replacement Procedure	11
5-4. SMA Rotary Joint Installation Procedure (Option 001)	12
5-5. Ordering Information	12
5-7. Direct Mail Order System	13

SAFETY SYMBOLS

The following safety symbols are used throughout this manual and in the instrument. Familiarize yourself with each of the symbols and its meaning before operating this instrument.



Instruction manual symbol. The instrument will be marked with this symbol when it is necessary for the user to refer to the instruction manual in order to protect the instrument against damage. Location of pertinent information within the manual is indicated by use of this symbol in the table of contents.



Indicates dangerous voltages are present. Be extremely careful.

CAUTION

The CAUTION sign denotes a hazard. It calls attention to a procedure which, if not correctly performed or adhered to, could result in damage to or destruction of the instrument. Do not proceed beyond a CAUTION sign until the indicated conditions are fully understood and met.

WARNING

The WARNING sign denotes a hazard. It calls attention to a procedure which, if not correctly performed or adhered to, could result in injury or loss of life. Do not proceed beyond a WARNING sign until the indicated conditions are fully understood and met.

1-1. GENERAL INFORMATION

1-2. Description

1-3. The HP 11940A Close-Field Probe is a hand-held, electromagnetic-field sensor designed to make repeatable, calibrated magnetic field measurements from 30 MHz to 1 GHz. It is optimized for the location and measurement of sources of electromagnetic interference (EMI) in electronic equipment. The HP 11940A can also be used as a localized magnetic field source when operated in conjunction with an appropriate signal generator, thereby allowing circuit board level susceptibility testing of instruments.

1-4. Options

1-5. The following options are offered to reduce measurement errors in high electromagnetic field impedance or field strength environments. Under these conditions, error signals created by leakage through the shielding of the interconnect cable could be a concern to the user. Options 001 and 002 work together to maintain proper cable shielding and ease of use. For less demanding applications, the use of a more flexible single-shielded cable type (e.g., RG-58, RG-174) is sufficient.

1-6. **Option 001** includes an SMA RF Rotary Joint connector (See Figure 11). The connector increases handling flexibility of the probe by removing any rotational torque from the interconnect cable. The Rotary Joint is especially useful when making measurements using double-shielded cable. Paragraph 5-4 includes instructions on installing the option.

HP Part Number 0955-0323
Check Digit 5

1-7. **Option 002** includes a 2m (6.6 ft) Double-Shielded RF Cable with two SMA (m) connectors. This double-shielded cable reduces error signals that may be coupled through the outer conductor of the coax.

HP Part Number 8120-4811
Check Digit 3

1-8. **Option 910** includes an additional Operation Note.

1-9. Initial Inspection

1-10. If the shipment contents are incomplete or damaged, notify the nearest Hewlett-Packard office. If the shipping container is damaged, or the cushioning material shows signs of stress, notify the carrier as well as the Hewlett-Packard office. Keep the shipping materials for the carrier's inspection. The HP office will arrange for repair or replacement without waiting for a claim settlement.

1-11. See Paragraph 4-1 for Operation Verification.

2-1. SPECIFICATIONS

2-2. Specifications for the HP 11940A are listed in Table 1. An asterisk (*) placed after an entry indicates a supplemental characteristic. Supplemental characteristics are not specifications but are characteristics included as additional information for the user.

2-3. Figure 1 illustrates the characteristic frequency response for the HP 11940A Close-Field Probe. See Section 3-4, Antenna Factors, for additional information.

Table 1. HP 11940A Specifications

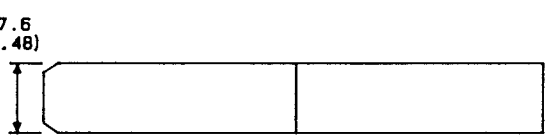
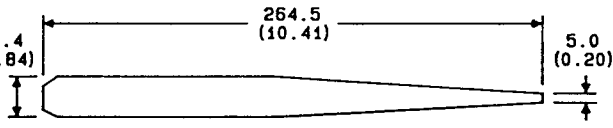
Antenna Factor:	Measured for each unit at 30, 100, 500, 850, and 1000 MHz to within ± 2 dB in a 377 ohm field impedance. See Figure 1 for characteristic antenna factor data.	
Temperature Range:*	0°C to +40°C: $< \pm 1$ dB (Operating) -10°C to +65°C (Storage)	
Frequency Range:	30 MHz-1 GHz	
Connector:	SMA, replaceable barrel	
Maximum Input Power:	0.5 watts	
VSWR:*	$< 3:1$	
Maximum voltage at tip:*	1 kV (dc + peak ac)	
Weight:*	Net: 0.10 kg (0.4 lbs) Shipping: 0.56 kg (1.2 lbs)	

DIMENSIONS IN MILLIMETERS AND (INCHES)

*supplemental characteristic

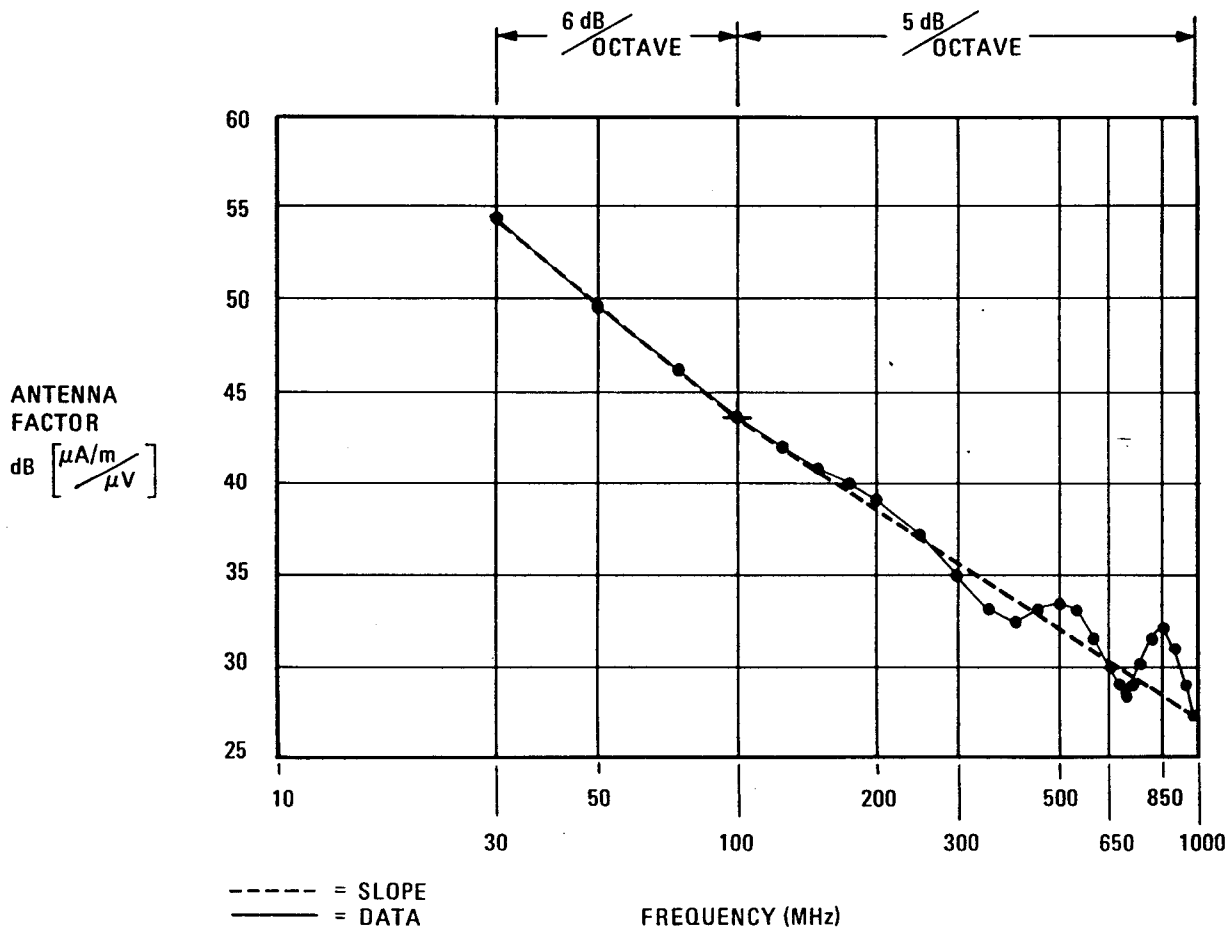

Figure 1. HP 11940A Characteristic Antenna Factors, 30 MHz-1 GHz

3-1. OPERATION

3-2. Theory of Operation

3-3. The HP 11940A is a balanced magnetic field sensor that provides an output voltage proportional to the strength of the magnetic field at its tip. Radiated magnetic fields couple directly to the HP 11940A and produce an output signal; radiated electric fields also couple to the HP 11940A but do not produce an output voltage due to the construction of the probe. The HP 11940A uses a dual-loop sensor and a balun to reject electrically coupled signals. See Figure 2. The probe preserves frequency information and is ideally suited for use with a spectrum analyzer. The HP 11940A circuitry is passive and therefore only contributes thermal noise to any measurement system. Inspect the probe tip for damage before using.

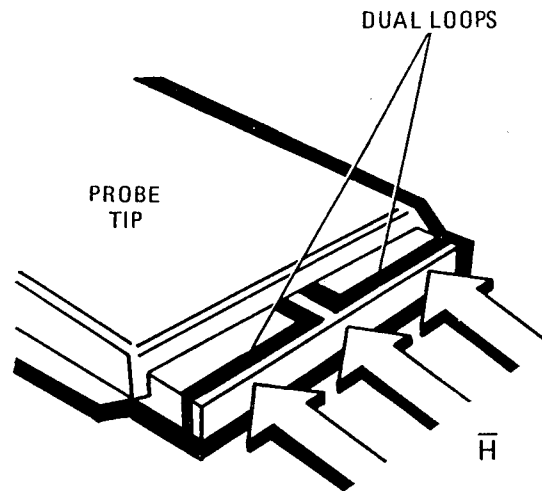

Figure 2. Magnetic Field Orientation for Maximum Coupling

3-4. Antenna Factors

3-5. The HP 11940A is supplied with a calibration table mounted on its side. The table provides antenna factors at five calibration points: 30 MHz, 100 MHz, 500 MHz, 850 MHz, and 1000 MHz. The antenna-factor units used in this table, $\text{dB}(\mu\text{A}/\text{m}/\mu\text{V})$, are accurate to ± 2 dB in a 377 ohm field impedance. Add the antenna-factor units to the measured voltage in $\text{dB}\mu\text{V}$ indicated on the spectrum analyzer to give magnetic-field strength in $\text{dB}(\mu\text{A}/\text{m})$. Refer to the following equation:

$$\bar{H}\text{-Field Strength} \left(\text{dB} \frac{\mu\text{A}}{\text{m}} \right) = V_{\text{SA}} + \text{AF} + \text{K}$$

where

V_{SA} = voltage in $\text{dB}\mu\text{V}$ measured on analyzer

AF = HP 11940A Antenna Factor in $\text{dB} \left(\frac{\mu\text{A}/\text{m}}{\mu\text{V}} \right)$

K = loss or gain in dB between HP 11940A and spectrum analyzer
(Positive value if loss, negative value if gain.)

3-6. Use the data included in Figure 1 for interpolating antenna factors between the five calibration frequencies included in the probe's calibration table.

3-7. The probe may be used below 30 MHz and above 1000 MHz without calibration and with reduced electric field rejection. See Figure 3 for characteristic antenna factors below 30 MHz.

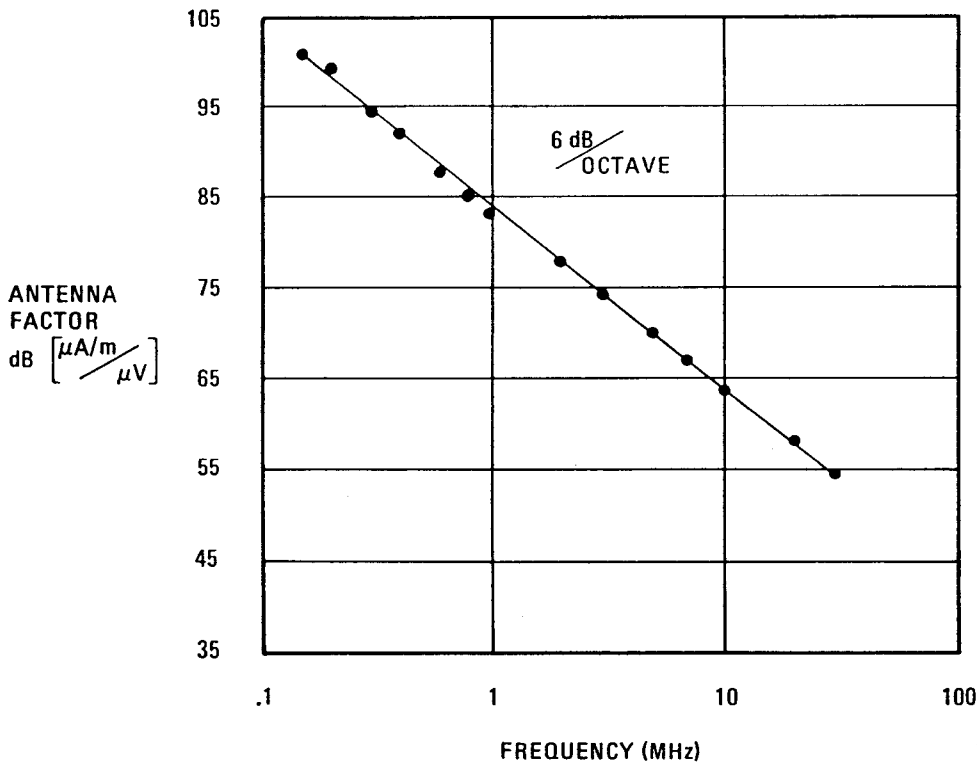

Figure 3. HP 11940A Characteristic Antenna Factors below 30 MHz

3-8. Power Density and Electric Field Calculations

3-9. The HP 11940A measures magnetic field strength. Assuming a 377-ohm field impedance, an associated electric field strength or a wave power density can be calculated from the magnetic field measurement. Refer to the following equations:

$$E\text{-Field Strength} \left(\text{dB} \frac{\mu\text{V}}{\text{m}} \right) = V_{SA} + AF + K + 51.5$$

$$\text{Power Density} \left(\text{dB} \frac{\text{mW}}{\text{cm}^2} \right) = V_{SA} + AF + K - 104.3$$

where

V_{SA} = voltage in $\text{dB}\mu\text{V}$ measured on analyzer

AF = HP 11940A Antenna Factor in $\text{dB} \left(\frac{\mu\text{A/m}}{\mu\text{V}} \right)$

K = loss or gain in dB between HP 11940A and spectrum analyzer
(Positive value if loss, negative value if gain.)

EXAMPLE:

At 100 MHz, measured $V_{SA} = 60.3 \text{ dB}\mu\text{V}$. Let $K = 0$ and $AF = 44 \text{ dB} \left(\frac{\mu\text{A/m}}{\mu\text{V}} \right)$

then
$$E \left(\text{dB} \frac{\mu\text{V}}{\text{m}} \right) = 60.3 + 44 + 51.5 = 155.8 \text{ dB}\mu\text{V/m} = 61.7 \text{ V/m}$$

$$S \left(\text{dB} \frac{\text{mW}}{\text{cm}^2} \right) = 60.3 + 44 - 104.3 = 0 \text{ dB} \frac{\text{mW}}{\text{cm}^2} = 1 \frac{\text{mW}}{\text{cm}^2}$$

3-10. Localized Field Source

3-11. The probe can also be used as a localized magnetic field source for locating susceptibility problems on an electronic circuit. It is a reciprocal device: that is, a voltage fed into the unit will create a magnetic field at the dual-loop sensor. For this application, the maximum input power is 0.5W with a characteristic worst-case VSWR of 3:1. Table 2 lists characteristic magnetic field strengths developed at the probe tip using 0 dBm incident power.

Table 2. Characteristic Magnetic Field Strengths

Frequency (MHz)	Input Power (incident)	Magnetic Field Strength (\vec{H}), dB ($\mu\text{A/m}$)
30	0 dBm	101
100	0 dBm	98
500	0 dBm	94
850	0 dBm	93
1000	0 dBm	98

3-12. Test Setups

3-13. The HP 11940A operates as either a localized magnetic field probe or localized magnetic field source. The following paragraphs describe different applications and test setups for the probe. Table 3 lists the recommended test setup equipment used in these examples. Any equipment that satisfies the critical specifications listed in Table 3 may be substituted for the recommended equipment. When used as a probe, be sure to add the antenna-factors and cable losses to the signal levels indicated on the spectrum analyzer. If a preamplifier is used to increase measurement sensitivity, subtract its gain from the displayed signal level.

WARNING

The dielectric material on the tip of the probe has a characteristic breakdown voltage of 1 kV. To prevent damage to the probe and/or personal injury to the user, the probe should not be used where a potential of over 1 kV is available.

3-14. Emissions Test Setup: Figure 4 illustrates the basic configuration used for detecting EMI emissions.

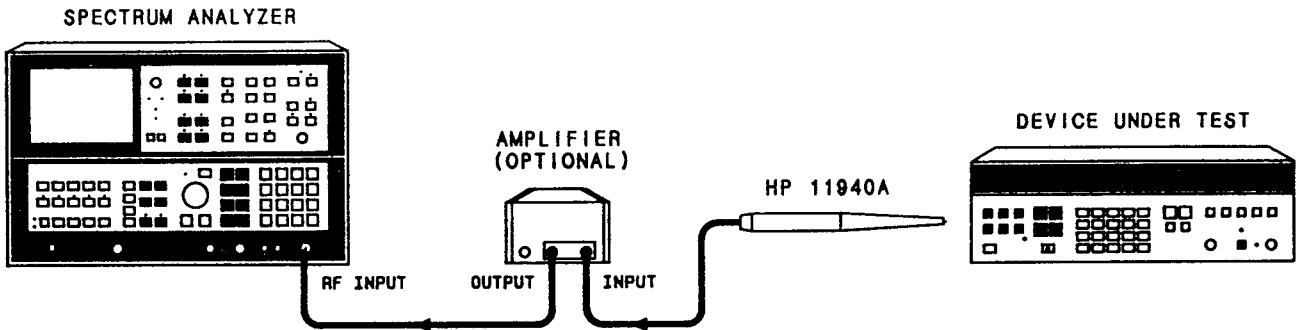

Figure 4. Emissions Test Setup

3-15. Stimulus Response Test Setup: The relative shielding effectiveness of various enclosures and shielded structures can be tested using stimulus response techniques. See Figure 5. The tracking generator output signal radiates from an antenna placed inside the enclosure under test, while the probe and spectrum analyzer provide frequency and relative amplitude information. See Section 3-17 for proper probe placement.

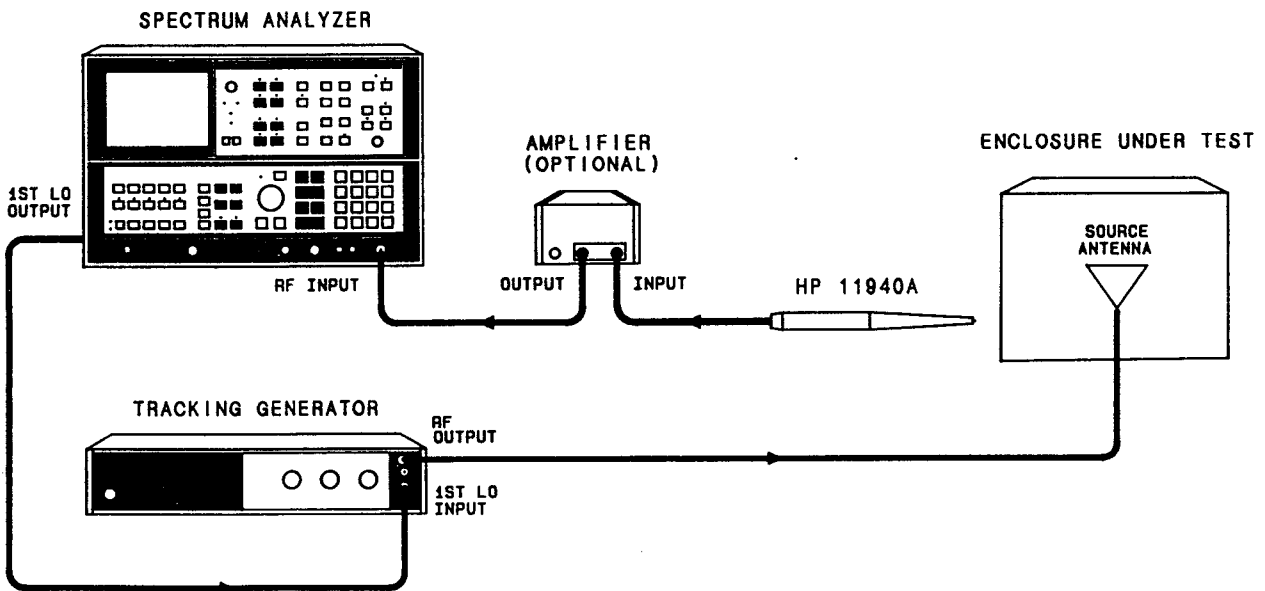

Figure 5. Stimulus Response Test Setup

3-16. Source Test Setup: Used as a field source, the probe provides a magnetic field for susceptibility testing of electronic circuits. For broadband susceptibility testing, use the probe with a swept or tracking source. See Figure 6 for an example of the basic localized field source test setup.

CAUTION

Power applied to the probe must not exceed the maximum input power listed in Table 1 or damage to the probe will result.

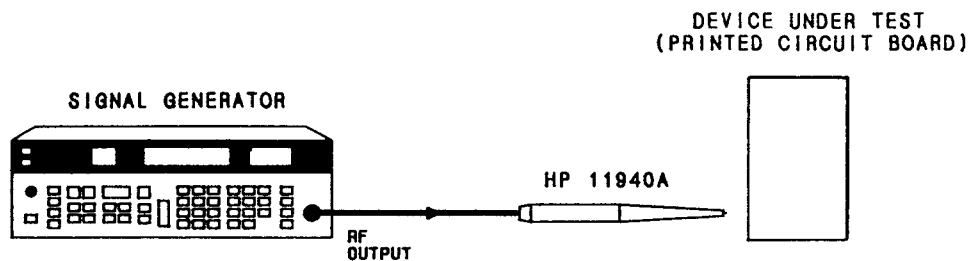

Figure 6. Source Test Setup

Table 3. Recommended Test Setup Equipment

Instrument	Critical Specifications	Recommended Model
Spectrum Analyzer	Frequency Range: 30 MHz–1 GHz	HP 8567A (10 kHz–1.5 GHz) HP 8568B (100 Hz–1.5 GHz) HP 8566B (100 Hz–22 GHz)
Tracking Generator	Frequency Range: 30 MHz–1 GHz	HP 8444A, Option 059 (100 MHz–1.5 GHz) for use with HP 8567A or HP 8568B
Signal Generator	Frequency Range: 30 MHz–1 GHz	HP 8656B (0.1–990 MHz)
Preamplifier*	Frequency Range: 30 MHz–1 GHz RF Gain: ≥ 20 dB	HP 8447D (100 kHz–1.3 GHz) (Gain ≥ 26 dB)
* HP 85685A RF Preselector may be substituted if a spectrum analyzer listed above is used.		

3-17. Measurement Techniques

3-18. The probe is designed to be held very close to potential radiating points. The plane of the probe tip loops must be perpendicular to the radiating magnetic field as illustrated in Figure 2. For example, if the seam of an enclosure is being tested for EMI, hold the probe as illustrated in Figure 7. When measuring the

radiation from a coaxial cable, position the probe tip as shown in Figure 8. The side of the probe with the calibration label should be facing away from the cable being measured.

3-19. The probe may be used as a source in susceptibility testing as described in Section 3-11 and Paragraph 3-16. In this application, hold the probe within 1 cm of the electronic circuit component being tested.

4-1. OPERATION VERIFICATION

4-2. Operation Verification for the HP 11940A consists of the Return Loss Measurement Test included in this section. Actual antenna factor verification requires a calibrated broadband magnetic field. A return loss measurement provides a reliable alternate method of determining the probe's electrical integrity. The test is performed over a frequency range where the VSWR is approximately 1.25:1 for a properly operating probe. Electrical damage is indicated by any large decrease in return loss (increase in VSWR) as specified in the test.

4-3. Probes that fail this test, although damaged, may still detect electromagnetic radiation. In this case, the antenna factors listed on the unit are no longer valid and the circuitry no longer rejects electric field coupling. Recalibration of the probe's antenna factors is not possible.

4-4. The HP 11940A contains no internal user-accessible adjustments or parts. The SMA Adapter (see Figure 10) is the only external replaceable part.

4-5. Return Loss Measurement Test

Description

This test measures the return loss of the HP 11940A over a frequency range of 30 MHz to 130 MHz. Measurement results at frequencies greater than 150 MHz are not valid. The HP 8750A Storage-Normalizer is optional and increases the ease of reading return loss measurements. Any equipment that satisfies the following critical specifications for the test setup may be substituted for the recommended equipment:

Frequency Range	200 MHz
Test Port Match	>22 dB Return Loss

Equipment

Network Analyzer	HP 8754A
Transmission/Reflection Test Set	HP 8502A
Storage-Normalizer (Optional)	HP 8750A

Adapters:

Type N (m) to SMA (f)	HP 1250-1250
Type SMA (m) to SMA (m)	HP 1250-1159
Type SMA (f) Coaxial Short	HP 0960-0054

Cables:

RF Cable Kit for HP 8502A	HP 11851A
-------------------------------------	-----------

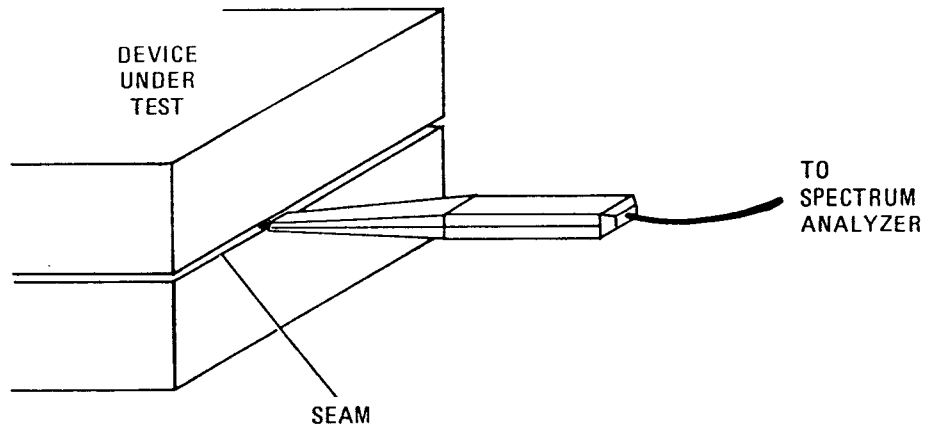

Figure 7. Testing an Enclosure Seam

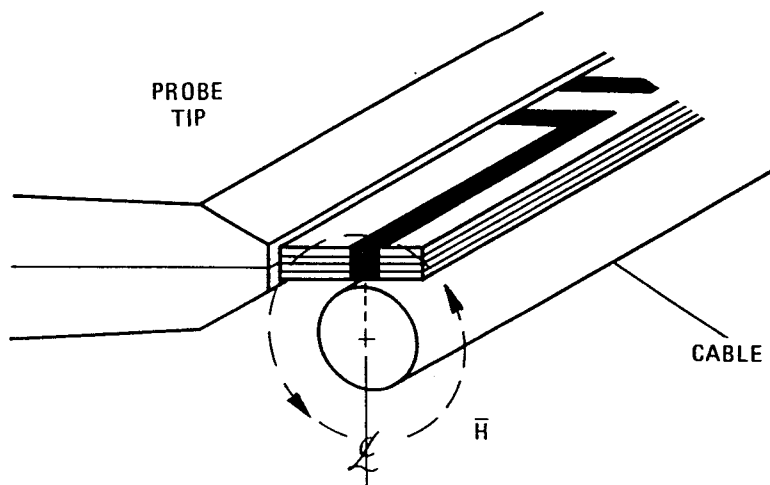
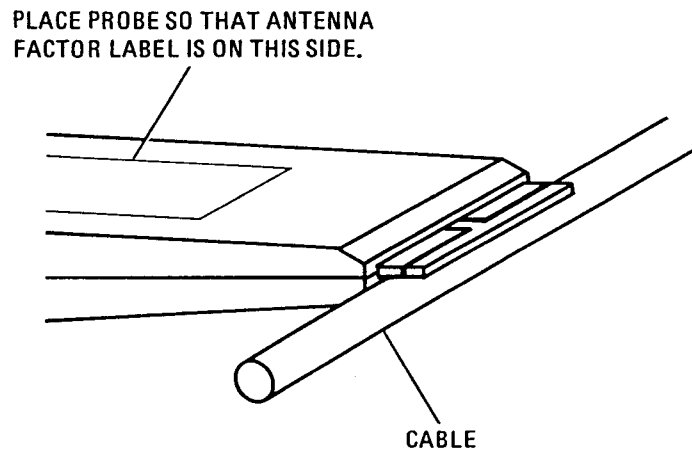

Figure 8. Testing a Coaxial Cable

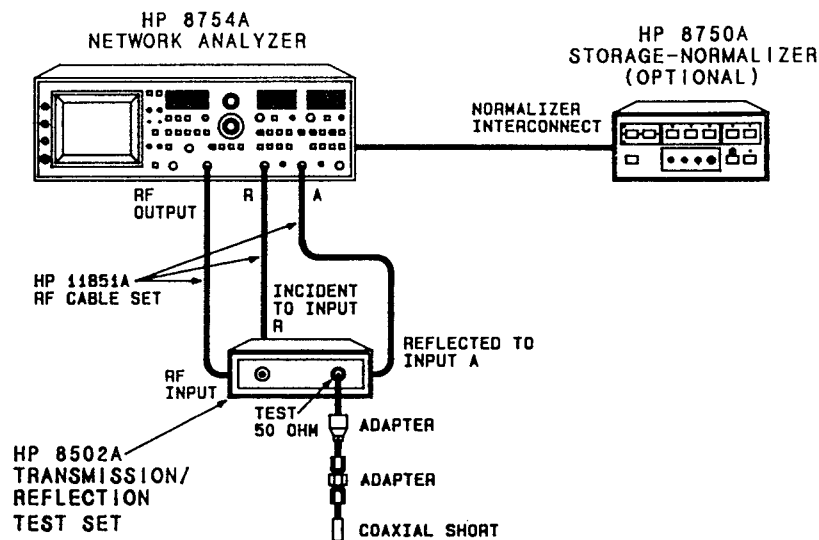

Figure 9. Return Loss Test Setup

Procedure

1. Connect the equipment as shown in Figure 9. Allow the HP 8754A 30 minutes of warm-up time.
2. If an HP 8750A Storage-Normalizer is used, adjust the normalizer's gain and position controls for the proper display on the network analyzer. Refer to the HP 8750A Operation and Service Manual for the adjustment procedure.
3. Set the HP 8754A controls as follows:

CH 1 REF POSITION ON
 POLAR CENTER OFF
 START ON
 TUNING 30 MHz
 SWEEP WIDTH 100 MHz
 SWEEP AUTO, FAST
 OUTPUT +10 dBm
 EXT FREQUENCY DOUBLER OFF

Channel 1
 A/R ON
 10 dB/DIV ON
 REFERENCE -00 dB
 POLAR A/R OFF

Channel 2 OFF

4. Set the HP 8502A Input Attenuation knob to 0 dB.
5. Adjust the HP 8754A trace to the top graticule line using the CH 1 REFERENCE POSITION knob. Turn the CH 1 REFERENCE POSITION off.
6. On the HP 8754A, turn on the CH 1 REFERENCE OFFSET. Adjust the trace, reference line, to the top CRT graticule using the REFERENCE OFFSET knob. The HP 8754A is now calibrated for making return loss measurements relative to the short.
7. If an HP 8750A Storage Normalizer is used, press the following keys on the HP 8750A: [CH 1], [INPUT], [STORE INPUT], and [INPUT-MEM]. The displayed reference line will shift to the middle of the screen. Errors in the reflection test set will now be normalized.
8. Remove the SMA Coaxial Short and replace it with the HP 11940A probe. The displayed trace should be 16 dB or more below the reference line at all frequencies. If the trace is less than 16 dB below the reference line, the probe fails the test.

5-1. REPLACEABLE PARTS

5-2. The SMA Adapter located at the end of the probe is the only replaceable part on the HP 11940A (see Figure 10). It protects the SMA Connector from mechanical damage and should be left on. Should the end of the adapter become worn or damaged through use, it can be replaced using the procedure outlined in Paragraph 5-3. The SMA Connector is not replaceable and should therefore be handled with care.

SMA Adapter	HP Part Number 1250-1158 Check Digit 3
Loctite 222®	HP Part Number 0470-0573 Check Digit 9

5-3. SMA Adapter Replacement Procedure

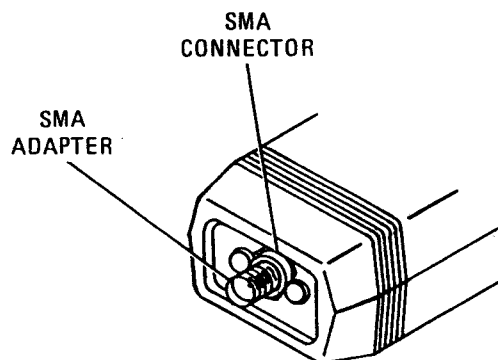

Figure 10. SMA Adapter Location

1. Use a 7/32" wrench to remove the old SMA Adapter (see Figure 10). Turn the adapter counterclockwise as viewed looking at the rear of the probe.

2. Place a small amount of Loctite 222® on two or three end threads of the new SMA Adapter.
3. Screw the new adapter clockwise onto the probe's SMA Connector.
4. Using a torque wrench, tighten the adapter to 24 inch-pounds.

5-4. SMA Rotary Joint Installation Procedure (Option 001)

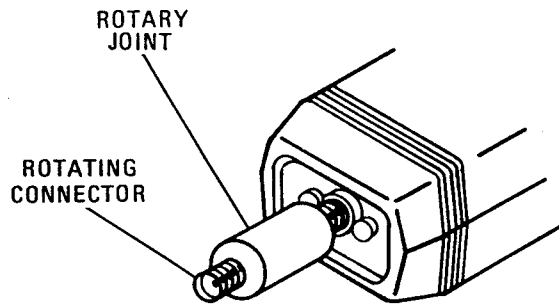

Figure 11. RF Rotary Joint Mounted on Probe (Option 001)

1. Use a 7/32" wrench to remove the old SMA Adapter (see Figure 10). Turn the adapter counterclockwise as viewed looking at the rear of the probe.
2. The SMA Rotary Joint has one SMA connector located at each end. One connector rotates with respect to the body of the Rotary Joint. The other connector is fixed to the body. Cover two or three end threads of the fixed end connector with a small amount of Loctite 222®.
3. Screw the fixed end of the Rotary Joint clockwise onto the probe's SMA Connector (see Figure 11).
4. Using a torque wrench, tighten the Rotary Joint to 24 inch-pounds.
5. When attaching a cable to the Rotary Joint, use a 17/64" wrench to keep the rotating connector from turning.

5-5. Ordering Information

5-6. To order a part, quote the Hewlett-Packard part number (with check digit), indicate the quantity required, and address the order to the nearest Hewlett-Packard office. The check digit will ensure accurate and timely processing of your order.

5-7. Direct Mail Order System

5-8. Within the USA, Hewlett-Packard can supply parts through a direct mail order system. Advantages of using the system are as follows:

- a. Direct ordering and shipment from the H-P Parts Center in Mountain View, California
- b. No maximum or minimum on any mail order (there is a minimum order amount for parts ordered through a local H-P office when the orders require billing and invoicing)
- c. Prepaid transportation (there is a small handling charge for each order)
- d. No invoices

To provide these advantages, a check or money order must accompany each order. Mail order forms and specific ordering information is available through your local HP office.

HEWLETT-PACKARD SALES AND SERVICE OFFICES

To obtain servicing information or to order replacement parts, contact the nearest Hewlett-Packard Sales and Service Office listed in the HP Catalog, or contact the nearest regional office listed below:

IN THE UNITED STATES

CALIFORNIA
P.O. Box 4230
1421 South Manhattan Avenue
Fullerton 92631

GEORGIA
P.O. Box 105005
2000 South Park Place
Atlanta 30339

ILLINOIS
5201 Tollview Drive
Rolling Meadows 60008

NEW JERSEY
W. 120 Century Road
Paramus 07652

IN CANADA

Hewlett-Packard (Canada) Ltd.
17500 South Service Road
Trans-Canada Highway
Kirkland, Quebec H9J 2M5

IN FRANCE

Hewlett-Packard France
F-91947 Les Ulis Cedex
Orsay

IN GERMAN FEDERAL REPUBLIC

Hewlett-Packard GmbH
Vertriebszentrale Frankfurt
Berner Strasse 117
Postfach 560 140
D-6000 Frankfurt 56

IN GREAT BRITAIN

Hewlett-Packard Ltd.
King Street Lane
Winnersh, Wokingham
Berkshire RG11 5AR

IN OTHER EUROPEAN COUNTRIES

SWITZERLAND
Hewlett-Packard (Schweiz) AG
29 Chemin Chateau Bloc
CH-1219 LeLignon-Geneva

IN ALL OTHER LOCATIONS

Hewlett-Packard Inter-Americas
3200 Hillview Avenue
Palo Alto, California 94304

